

TECO

INDUCTION MOTORS

EXPLOSION-PROOF



**UNDERWRITERS LABORATORIES INC. LISTED
HAZARDOUS LOCATIONS**

Class I: Group D

Class II: Groups E, F, & G

NEMA Frames 143T-445T

3/4 HP through 150 HP

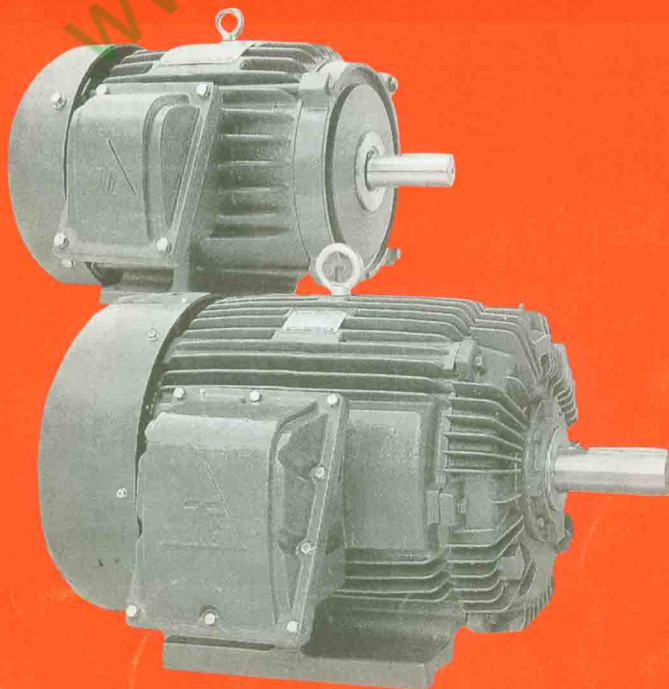

PREMIUM FEATURES

- Rugged Cast-Iron Construction
- Oversized cast-Iron Conduit Box
- Oversized Vacuum Degassed Bearings
- Stainless Steel Nameplate and UL Dual Class Label
- Non-sparking Fan and Dust Slingers
- Low Temperature Rise
- Energy Efficient and High Power Factor
- Usable on 208 Volts
- 1.15 Service Factor
-  Certified through 75 HP

Explosion-proof, Type AEEAXU

3/60/230-460V (usable on 208V); 575V

Class I-Group D and Class II-Groups E, F, G

NEMA Design B, Class B & F Insulation*

40° C Ambient Temperature, Continuous duty, 1.15 Service Factor

HP	Full Load RPM	Frame Size	Full Load				Locked Rotor		Break-down Torque %FLT	Rotor WR ² 1b-ft ²	NEMA Code Letter	Approx. NET WT. LBS.
			Torque 1b-ft	Eff. %	P.F. %	Current Amps @ 460V	Torque %FLT	Current Amps @ 460V				
¾	1150	143T	3.4	74.0	61.5	1.5	175	12.5	285	0.080	P	66
	1750	143T	3.0	77.0	76.0	1.6	275	15.0	360	0.063	N	66
	1160	145T	4.5	75.5	60.5	2.0	250	15.0	350	0.105	N	73
1	3470	143T	2.3	80.0	86.0	2.0	350	20.0	370	0.050	M	69
	1720	145T	4.6	77.0	78.5	2.3	250	20.0	300	0.085	M	69
	1150	182T	6.9	75.5	77.5	2.4	165	20.0	280	0.200	M	106
2	3460	145T	3.0	81.5	87.5	2.6	245	25.0	270	0.065	L	73
	1715	145T	6.1	80.0	81.5	2.9	235	25.0	295	0.105	L	73
	1160	184T	9.1	80.0	74.5	3.1	170	25.0	315	0.300	L	115
3	3410	182T	4.6	78.5	90.5	4.0	210	32.0	270	0.125	K	106
	1750	182T	9.0	84.0	79.5	4.2	235	32.0	340	0.220	K	106
	1170	213T	13.5	85.5	74.5	4.4	205	32.0	315	0.360	K	170
5	3460	184T	7.6	82.5	93.0	6.1	200	46.0	270	0.235	J	117
	1735	184T	15.1	85.5	86.5	6.3	210	46.0	300	0.395	J	117
	1155	215T	22.7	84.0	78.5	7.1	190	46.0	290	0.925	J	183
7½	3475	213T	11.3	84.0	89.5	9.3	215	63.5	235	0.280	H	190
	1745	213T	22.6	86.5	89.5	9.1	190	63.5	250	0.695	H	190
	1170	254T	33.7	86.5	85.0	9.6	190	63.5	235	1.710	H	291
10	3465	215T	15.2	85.5	90.5	12.4	200	81.0	240	0.380	H	216
	1745	215T	30.1	87.5	90.5	11.8	210	81.0	260	0.955	H	220
	1170	256T	44.9	87.5	84.5	12.7	200	81.0	250	2.550	H	324
15	3510	254T	22.5	86.5	91.5	17.7	200	116.0	220	0.990	G	300
	1750	254T	45.0	88.5	90.5	17.5	205	116.0	250	1.950	G	315
	1165	284T	67.6	88.5	82.5	19.2	190	116.0	220	4.100	G	436
20	3515	256T	29.9	88.5	91.5	23.1	195	145.0	220	1.300	G	357
	1750	256T	60.0	90.2	90.5	22.9	210	145.0	240	2.450	G	359
	1170	286T	89.8	90.2	85.5	24.3	210	145.0	210	7.550	G	502
25	3505	284TS	37.5	88.5	91.0	29.1	185	182.5	220	1.600	G	447
	1750	284T	75.1	90.2	88.5	29.3	210	182.5	245	3.750	G	456
	1170	324T	112.0	91.7	82.5	30.9	185	182.5	215	8.700	G	682
30	3520	286TS	45.0	88.5	91.0	34.9	200	217.5	220	2.100	G	502
	1755	286T	90.0	90.2	90.0	34.6	195	217.5	220	4.600	G	513
	1170	326T	135.0	91.0	85.5	36.1	190	217.5	220	11.800	G	726
40	3550	324TS	59.0	89.5	89.0	47.0	160	290.0	230	3.000	G	691
	1760	324T	119.0	91.0	90.0	45.7	190	290.0	220	6.700	G	735
	1180	364T	178.0	92.4	85.0	47.7	190	290.0	200	15.600	G	902
50	3545	326TS	74.0	89.5	92.0	53.9	185	362.5	220	3.460	G	733
	1765	326T	149.0	91.7	90.5	56.4	190	362.5	230	7.950	G	803
	1175	365T	224.0	91.7	86.5	59.0	195	362.5	200	17.940	G	951
	875	404T	300.0	92.4	80.0	63.0	150	362.5	220	24.500	G	1080
60	3525	364TS	89.0	89.5	94.0	66.8	120	435.0	200	5.450	G	889
	1765	364T	179.0	93.0	87.5	69.0	170	435.0	210	10.800	G	902
	1170	404T	269.0	93.0	84.0	72.0	150	435.0	220	23.100	G	1100
	875	405T	360.0	92.4	80.0	76.0	150	435.0	220	30.000	G	1260
75	3540	365TS	111.0	91.0	93.0	83.0	120	542.5	205	8.050	G	933
	1770	365T	223.0	94.1	86.5	86.3	190	542.5	215	14.700	G	946
	1170	405T	336.0	93.0	84.0	90.0	150	542.5	220	28.900	G	1300
	880	444T	447.0	93.0	81.5	93.0	150	542.5	220	49.200	G	1620
100	3550	405TS	148.0	93.0	89.5	112.0	105	725.0	220	10.900	G	1210
	1770	405T	296.0	93.0	87.5	115.0	150	725.0	220	25.000	G	1370
	1175	444T	447.0	93.0	85.5	118.0	150	725.0	220	50.700	G	1650
	880	445T	596.0	93.0	82.5	122.0	150	725.0	220	64.000	G	1870
125	3555	444TS	185.0	93.0	90.2	140.0	100	907.5	220	16.000	G	1480
	1775	444T	370.0	93.6	87.5	143.0	140	907.5	220	37.900	G	1620
	1175	445T	558.0	93.6	85.5	146.0	150	907.5	220	62.000	G	1870
150	3555	445TS	221.0	93.0	90.2	167.0	100	1085	220	19.000	G	1680
	1775	445T	443.0	93.6	87.5	171.0	140	1085	220	45.500	G	1780

* Class F Insulation is standard for frames 143T-365T and Class F for frames 404T-445T

Note:

1. The above are typical values based on test
2. Actual load & full voltage starting: According to ANSI/IEEE standard 112-1978 method B
3. 150HP is 460 V or 575V only
4. Data subject to change without notice

Explosion-Proof Horizontal Foot-Mounted, Type AEEAXU

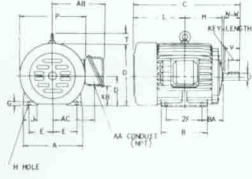

Figure 1

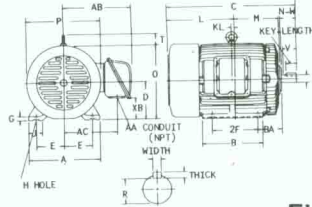

Figure 2

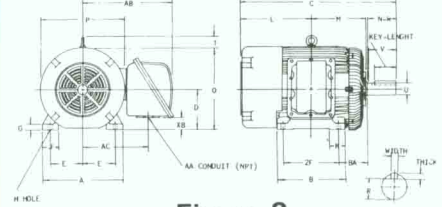

Figure 3

DIMENSIONS IN INCHES

OUTPUT (HP)				Frame Size	Fig. No.	MOUNTING				A	B	C	D	G	J	K	KL	L
2P	4P	6P	8P			E	2F	H	BA									
1½	1	¾	—	143T	1	2.75	4.00	.34	2.25	6.70	5.10	12.30	3.50	.35	1.40	—	—	5.80
2	1½/2	1	—	145T		2.75	5.00	.34	2.25	6.70	5.90	13.35	3.50	.35	1.40	—	—	6.35
3	3	1½	—	182T		3.75	4.50	.41	2.75	8.80	5.90	14.70	4.50	.65	1.75	—	—	6.95
5	5	2	—	184T		3.75	5.50	.41	2.75	8.80	6.90	15.75	4.50	.65	1.75	—	—	7.50
7½	7½	3	—	213T	1	4.25	5.50	.41	3.50	9.85	6.90	17.98	5.25	.70	1.75	—	—	8.35
10	10	5	—	215T		4.25	7.00	.41	3.50	9.85	8.35	19.48	5.25	.70	1.75	—	—	9.10
15	15	7½	—	254T		5.00	8.25	.53	4.25	11.80	9.85	23.38	6.25	0.65	1.95	—	—	11.00
20	20	10	—	256T		5.00	10.00	.53	4.25	11.80	11.80	25.15	6.25	0.65	1.95	—	—	11.90
—	25	15	—	284T	2	5.50	9.50	.53	4.75	14.00	11.80	26.87	7.00	0.70	2.95	—	—	12.75
25	—	—	—	284TS		5.50	9.50	.53	4.75	14.00	11.80	25.50	7.00	0.70	2.95	—	—	12.75
—	30	20	—	286T		5.50	11.00	.53	4.75	14.00	13.20	28.37	7.00	0.70	2.95	—	—	13.50
30	—	—	—	286TS		5.50	11.00	.53	4.75	14.00	13.20	27.00	7.00	0.70	2.95	—	—	13.50
—	40	25	—	324T	2	6.25	10.50	.66	5.25	15.75	12.80	30.00	8.00	1.10	3.15	—	—	14.25
40	—	—	—	324TS		6.25	10.50	.66	5.25	15.75	12.80	28.50	8.00	1.10	3.15	—	—	14.25
—	50	30	—	326T		6.25	12.00	.66	5.25	15.75	14.35	31.50	8.00	1.10	3.15	—	—	15.00
50	—	—	—	326TS		6.25	12.00	.66	5.25	15.75	14.35	30.00	8.00	1.10	3.15	—	—	15.00
—	60	40	—	364T	2	7.00	11.25	.66	5.88	17.70	13.60	33.63	9.00	1.30	3.55	—	.50	16.25
60	—	—	—	364TS		7.00	11.25	.66	5.88	17.70	13.60	31.50	9.00	1.30	3.55	—	.50	16.25
—	75	50	—	365T		7.00	12.25	.66	5.88	17.70	14.75	33.63	9.00	1.30	3.55	—	—	15.75
75	—	—	—	365TS		7.00	12.25	.66	5.88	17.70	14.75	31.50	9.00	1.30	3.55	—	—	15.75
—	100	75	60	404T	3	8.00	12.25	.81	6.62	19.70	15.15	36.69	10.00	1.55	3.95	3.75	—	16.70
—	100	75	60	405T		8.00	13.75	.81	6.62	19.70	16.75	38.19	10.00	1.55	3.95	3.75	—	17.45
100	—	—	—	405TS		8.00	13.75	.81	6.62	19.70	16.75	35.19	10.00	1.55	3.95	3.75	—	17.45
—	125	100	75	444T		9.00	14.50	.81	7.50	22.00	17.50	42.05	11.00	1.55	4.35	4.35	—	18.80
—	125	—	—	444TS	9.00	14.50	.81	7.50	22.00	17.50	38.30	11.00	1.55	4.35	4.35	—	18.80	
—	150	125	100	445T	9.00	16.50	.81	7.50	22.00	19.50	44.05	11.00	1.55	4.35	4.35	—	19.80	
—	150	—	—	445TS	9.00	16.50	.81	7.50	22.00	19.50	40.30	11.00	1.55	4.35	4.35	—	19.80	
Frame Size	M	O	P	T	KEY			KEYSEAT	CONDUIT BOX			SHAFT EXTENSION						
					WIDTH	THICK	LENGTH	R	AA	AB	AC	XB	N-W	U	V			
143T	4.00	7.50	8.03	—	.1875	.1875	1.41	0.771	¾	7.65	5.70	1.35	2.25	0.875	2.20			
145T	4.50	7.50	8.03	—	.1875	.1875	1.41	0.771	¾	7.65	5.70	1.35	2.25	0.875	2.20			
182T	4.85	9.35	9.60	1.15	.2500	.2500	1.78	0.986	¾	8.40	6.45	2.35	2.75	1.125	2.70			
184T	5.35	9.35	9.60	1.15	.2500	.2500	1.78	0.986	¾	8.40	6.45	2.35	2.75	1.125	2.70			
213T	6.05	10.80	11.10	1.45	.3125	.3125	2.41	1.201	1	10.60	7.45	2.25	3.38	1.375	3.30			
215T	6.80	10.80	11.10	1.45	.3125	.3125	2.41	1.201	1	10.60	7.45	2.25	3.38	1.375	3.30			
254T	8.20	12.70	12.90	1.75	.3750	.3750	2.91	1.416	1¼	12.10	8.95	3.10	4.00	1.625	3.90			
256T	9.05	12.70	12.90	1.75	.3750	.3750	2.91	1.416	1¼	12.10	8.95	3.10	4.00	1.625	3.90			
284T	8.95	14.20	14.35	1.90	.5000	.5000	3.28	1.591	1½	13.05	9.90	3.85	4.62	1.875	4.50			
284TS	8.95	14.20	14.35	1.90	.3750	.3750	1.93	1.416	1½	13.05	9.90	3.85	3.25	1.625	3.20			
286T	9.70	14.20	14.35	1.90	.5000	.5000	3.28	1.591	1½	13.05	9.90	3.85	4.62	1.875	4.50			
286TS	9.70	14.20	14.35	1.90	.3750	.3750	1.93	1.416	1½	13.05	9.90	3.85	3.25	1.625	3.20			
324T	10.10	16.10	16.20	2.10	.5000	.5000	3.91	1.845	2	15.95	11.60	3.55	5.25	2.125	5.15			
324TS	10.10	16.10	16.20	2.10	.5000	.5000	2.03	1.591	2	15.95	11.60	3.55	3.75	1.875	3.65			
326T	10.80	16.10	16.20	2.10	.5000	.5000	3.91	1.845	2	15.95	11.60	3.55	5.25	2.125	5.15			
326TS	10.80	16.10	16.20	2.10	.5000	.5000	2.03	1.591	2	15.95	11.60	3.55	3.75	1.875	3.65			
364T	11.40	18.05	18.15	2.90	.6250	.6250	4.28	2.021	3	16.75	12.40	4.50	5.88	2.375	5.75			
364TS	11.40	18.05	18.15	2.90	.5000	.5000	2.03	1.591	3	16.75	12.40	4.50	3.75	1.875	3.65			
365T	11.90	18.05	18.15	2.90	.6250	.6250	4.28	2.021	3	16.75	12.40	4.50	5.88	2.375	5.75			
365TS	11.90	18.05	18.15	2.90	.5000	.5000	2.03	1.591	3	16.75	12.40	4.50	3.75	1.875	3.65			
404T	12.25	20.30	20.60	2.50	.750	.750	5.67	2.450	3	19.90	14.85	4.35	7.25	2.875	7.15			
405T	13.00	20.30	20.60	2.50	.750	.750	5.67	2.450	3	19.90	14.85	4.35	7.25	2.875	7.15			
405TS	13.00	20.30	20.60	2.50	.5000	.5000	2.80	1.845	3	19.90	14.85	4.35	4.25	2.125	4.15			
444T	14.30	22.50	23.00	3.25	.875	.875	6.93	2.880	3	21.05	16.00	5.10	8.50	3.375	8.40			
444TS	14.30	22.50	23.00	3.25	.625	.625	3.03	2.021	3	21.05	16.00	5.10	4.75	2.375	4.70			
445T	15.25	22.50	23.00	3.25	.875	.875	6.93	2.880	3	21.05	16.00	5.10	8.50	3.375	8.40			
445TS	15.25	22.50	23.00	3.25	.625	.625	3.03	2.021	3	21.05	16.00	5.10	4.75	2.375	4.70			

Note:

(1) Dimension D tolerance: +0.00inch - 0.03inch (Frames 143T - 365T)
+0.00inch - 0.06inch (Frames 404T - 445T)

(2) Dimension U tolerance: +0.000inch - 0.0005inch (Frames 143T - 215T)
+0.000inch - 0.001inch (Frames 254T - 445T)

(3) Dimension R tolerance: +0.000inch - 0.015 inch

(4) Dimension V is the length of straight part of shaft

All data subject to change without notice. For construction use only certified data.

Typical Construction and Features, Type AEEAXU

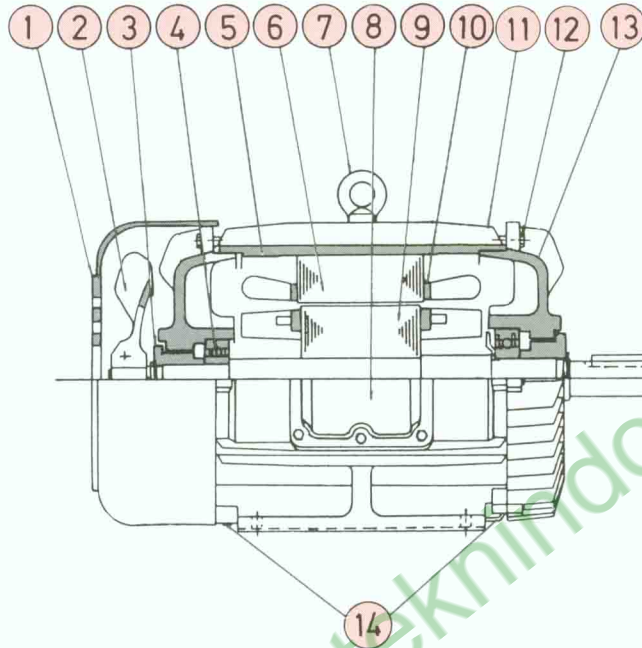

- | | |
|---|---------------------------------------|
| ① Cast Iron Fan Cover | ⑧ Oversized Cast Iron Conduit Box |
| ② Non-sparking External Fan | ⑨ Dynamically Balanced Die-cast Rotor |
| ③ Non-sparking Dust Flinger | ⑩ Improved Non-hydroscopic Insulation |
| ④ Oversized Bearings | ⑪ Efficient Close-High-Fins Design |
| ⑤ Cast-Iron frame | ⑫ Zn-Cd Plated Hardware |
| ⑥ Copper Winding and Electro-magnetic Steel Laminations | ⑬ Cast Iron Endbells |
| ⑦ Forged Eye-bolt | ⑭ Stainless Breather and Drains |

Hazardous Locations Listed by

Class	Group	Explosive Environment
I	D	Atmospheres Containing gasoline, hexane, naphtha, benzine, butane, propane, alcohols, acetone, benzol, lacquer solvent vapors, or natural gas.
II	E	Atmospheres containing dusts of aluminum, magnesium, or their commercial alloys.
	F	Atmospheres containing carbon black, coal, or coke dust.
	G	Atmospheres containing flour, starch, or grain dust.

All motors comply with operating temperature code T2D for Group D and T3B for Group E.F.G.

TECO ELECTRIC & MACHINERY CO., LTD.

5F,19-9,SAN CHONG RD, NAN-KANG,TAIPEI 115,TAIWAN,ROC

FAX : (02)2655-2231~2

TELEPHONE : (02)2655-3333

http : //www.teco.com.tw