

ISUZU 6BGIT

INDUSTRIAL DIESEL

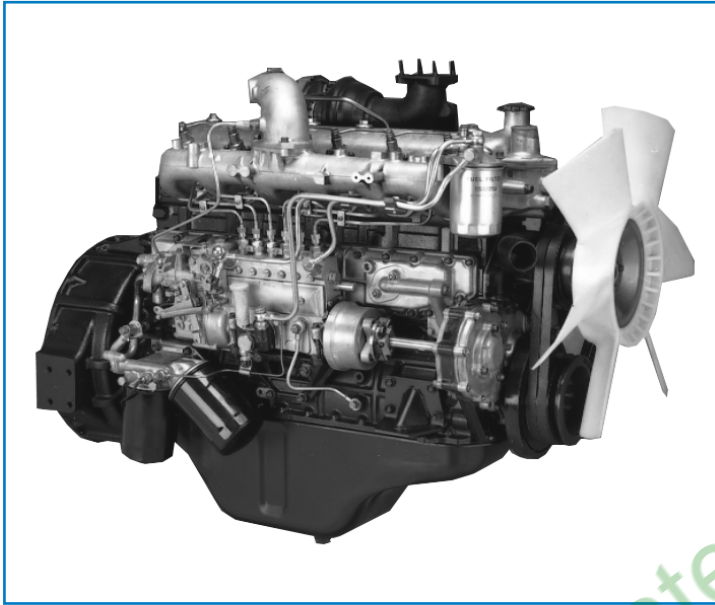

MAIN SPECIFICATIONS

| | |
|---------------------------|--|
| Type | 6 Cylinder, 4 Cycle, Water Cooled, OHV, Vertical In-Line, Direct Injection |
| Bore & Stroke | 4.13 x 4.92 in. (105 mm x 125 mm) |
| Piston Displacement | 396.3 cu. in. (6.5 l) |
| Compression Ratio | 17.5:1 |
| Dry Weight | 1088 lbs. (494 kg) |
| Dimensions (L x W x H) | 46.4 x 27.2 x 37.5 in. (1179 x 691 x 951.5 mm) |
| Coolant Capacity | 12.7 qt. (12 l) |
| Lube Oil Capacity | 22.7 qt. (21.5 l) |
| Engine Rotation Direction | Counter Clockwise from Flywheel |

MAIN FEATURES (Standard)

| | |
|-------------------|--|
| Alternator | 12V - 60A |
| Voltage Regulator | Internal |
| Starter | 12V - 2.5 kW |
| Exhaust Outlet | Center Upward |
| Air Inlet | Integral |
| Flywheel Housing | SAE #3 Type (w/metric threads) |
| Flywheel | SAE Type for 11.5" over center clutch (w/metric threads) |
| Oil Pan | 35° Inclination all directions |
| Water Outlet | Upward |
| Fan | 23.6 in. (600 mm) Suction |

INDUSTRIAL RATING*

| | |
|--------------|------------------------|
| Intermittent | 174 BHP @ 2500 RPM |
| Continuous | 154 BHP @ 2500 RPM |
| Max Torque | 443 lb. ft. @ 1800 RPM |

*SAE J1995 Gross BHP

Specifications subject to change without notice.

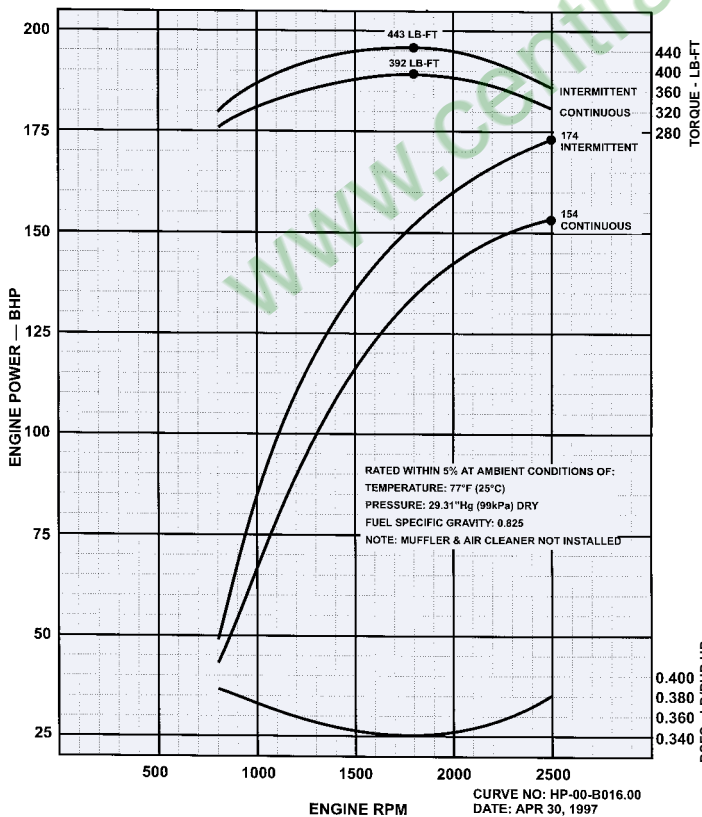

AMERICAN ISUZU MOTORS INC.

PowerTrain Division

ISUZU
DIESEL

46401 COMMERCE CENTER DRIVE • PLYMOUTH, MI 48170
 PHONE: (734) 582-9470 • FAX: (734) 455-7581
www.isuzuengines.com

ISUZU 6BGIT

INDUSTRIAL DIESEL

DIMENSIONS

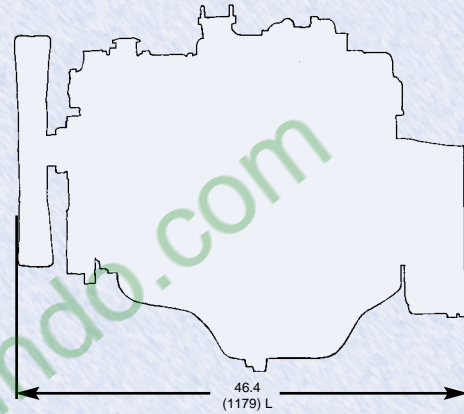
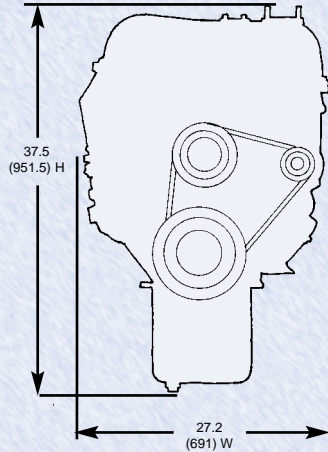

ISUZU "B" SERIES SPECIAL FEATURES

- Direct Injection
- Replaceable Cromard Dry Liners
- Oil Cooled Pistons
- Tuftrided Crankshaft
- Glow Plug Starting Assist

LOW EMISSIONS

- Modified Combustion Chamber Design
- Optimized Injection Timing with Zexel A-Type In-Line Pump
- RSV Governor

QUIET OPERATION

- New Injection Timing System
- High-rigidity Cast Iron Cylinder Block
- Helical Timing Gears have a Minimum of Backlash

ADDITIONAL FEATURES

- All New B Models have Identical Accessory Drive Configurations
- High-Efficiency Turbocharged Eliminate Need for Wastegate Mechanisms
- Maximum Parts Commonality among All B Models

ISUZU
DIESEL

AMERICAN ISUZU MOTORS INC.

PowerTrain Division

46401 COMMERCE CENTER DRIVE • PLYMOUTH, MI 48170
PHONE: (734) 582-9470 • FAX: (734) 455-7581
www.isuzuengines.com